

The 6th  
**INTERNATIONAL  
COIN-OPERATED  
LAUNDRY  
EXPO 2021**

The 6th Coin-operated Laundry EXPO 2021

The 5th  
**CLEAN**  
BUSINESS FORUM 2021

The 5th Clean Business Forum 2021

**EXHIBITION GUIDE**

2021  
**Sep. 15 Wed. > 16 Thur.**

Sep. 15 10:00-17:00  
Sep. 16 10:00-16:00

INTEX Osaka Hall 3

**2019 Show Results**

**Number of exhibitors**

**63 companies 174 booths**  
-International Coin-operated Laundry EXPO 29 companies 109 booths  
-Clean Business Forum 34 companies 65 booths

**Number of Visitors (registered / counted)**

**Registered 5,960 / Counted 10,365**  
\*The above number includes visitors of joint exhibition.

**Visitor's categories**

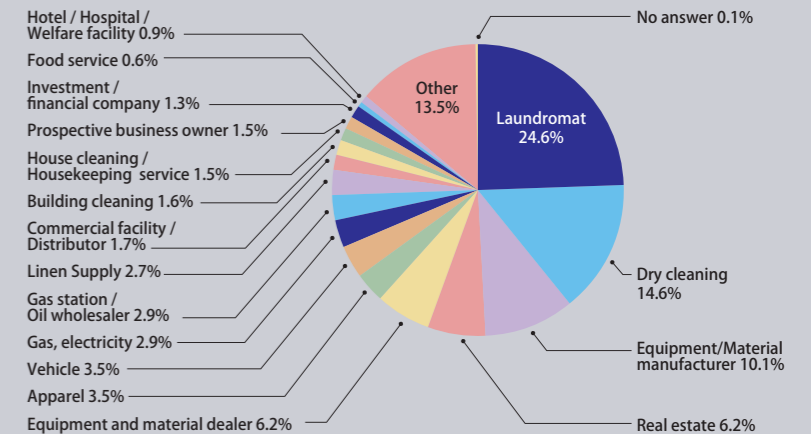

**Exhibition Booth Fee**

**Booth space**

**JPY286,000**  
(tax included) / booth (9m<sup>2</sup> 3m x 3m)

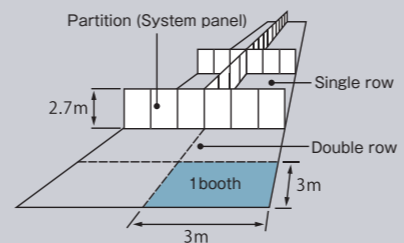

**Shell scheme (1 · 2 booths)**

**1 booth / JPY88,000**  
(tax included)

- Carpet
- Parapet (White) x 1
- Company name board (gothic) x 1
- Reception counter x 1
- Folding chair x 2
- Visiting card box x 1
- Spotlight x 1
- Fluorescent light (40W) x 2
- Outlet x 1

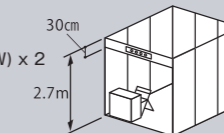

**2 booth / JPY154,000**  
(tax included)

- Carpet
- Parapet (White) x 1
- Company name board (gothic) x 1
- Reception counter x 1
- Folding chair x 2
- Visiting card box x 1
- Spotlight x 2
- Fluorescent light (40W) x 4
- Outlet x 2

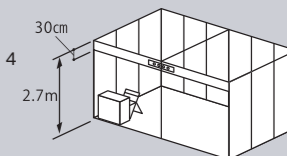

**Discount**

**Early Bird : JPY11,000 / booth** (Deadline : April 30, 2021)

**2019 Exhibitor : JPY33,000 / booth**

**Sterilization / Hygiene control stand**

Reasonable stand area specialized for sterilization and hygiene control products

**Exhibit fee**

**JPY110,000 / unit**

- \*Only for companies dealing with sterilization and hygiene control products and services.
- \*As a general rule, more than 2 units will be set up close together.
- \*If you would like to order other than the figure on the right, contact to the show management office to request for quotation.
- \*Please read Exhibition Rules on the back of application form before applying.

**A stand unit includes:**

- Parapet (White) w99cm x h2.7m x 1
- Display counter (small storage with sliding doors) (White) w99cm x d70cm x h75cm x 1
- Company name board (Gothic/Black) w95cm x h20cm x 1
- Spotlight 75W x 1
- Outlet 100V (2 sockets) x 1
- Electricity.....500W

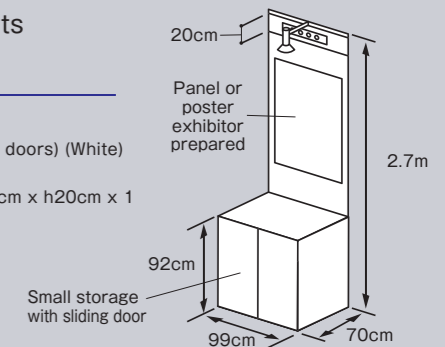

**Schedule**

2020  
November  
Start Applying  
for Exhibition

2021  
April 30th  
(Fri.)  
Early Bird  
Deadline

June 30th  
(Wed.)  
Application  
Deadline

September  
15 - 16

Contact

**Show Management Office**

c/o JC Resonance Co., Ltd. News Tsukiji 9F, Chuo-ku, Tokyo 104-0045, Japan E-mail:office@jc-resonance.co.jp

The 6th  
INTERNATIONAL  
COIN-OPERATED  
LAUNDRY  
EXPO 2021

The only coin-operated laundry trade show in Japan

Showcase of the latest products and services

First show in Osaka, western Japan!



The number of laundromats is increasing year by year in Japan. Additionally, collaboration with other services, for example gas station, cafe, commercial facility, convenience store become common.



6th awards for coin-operated laundry shop will be held during the show.

Prospective Exhibitors

- Machine / Equipment manufacturer
- Materials manufacturer
- Equipment and materials dealer
- Trading house / Agent (companies promoting coin-operated laundry business)
- Detergent manufacturer
- Franchiser / Franchisee
- Other (Store design, Security service provider, IT equipment supplier, System vendor, Delivery locker etc.)

Prospective Visitors

- Coin-operated laundry owner
- Hotel / Hospital / Welfare facility
- Real estate
- Dry cleaner owner
- Franchise shop owner
- Commercial facility / Retail industry
- Investment company / Financial institution
- Gas station / Oil wholesaler
- Gas, electricity supplier
- Other
  - \*Considering investing in the business
  - \*Considering opening laundry
  - \*Looking for ways for land utilization
  - \*Considering joining franchise chain, etc.

The 5th  
CLEAN  
BUSINESS FORUM 2021

Creating new value for cleaning business field

Find business partners  
Meet business professionals and find new biz partners

Discover the latest cleaning business information  
Get the latest market trend



Prospective Exhibitors

- Equipment manufacturer
- Materials manufacturer
- Equipment / Material trading firm
- Store design / Security
- IT related equipment supplier
- System vendor
- Cleaning business
- Sterilization / Hygiene control

Prospective Visitors

- Linen supply
- Coin-operated laundry
- Apparel
- Dry cleaning
- Automobile (car cleaning etc.)
- Machinery / Material manufacturer
- Building cleaning
- Hotel / Hospital / Welfare facility
- Equipment / Material trading house
- House cleaning
- Commercial facility / Retail industry
- Housekeeping service
- Restaurant / Food processing factory